



# TRITON

## EL SERIES AMPLIFIERS

EL6002

---





Congratulations and thank you for purchasing Triton mobile amplifier. With a focus on quality, innovation, and value, Triton amplifiers feature a no-compromise design built for today's music. , Triton Audio makes no compromises in delivering incredibly accurate sound from a compact chassis.

To make sure your new amplifier performs its best, we strongly recommend you have your new Triton amplifier professionally installed.

Please use your new Triton amplifier responsibly. Listening to very loud music for extended periods of time can cause permanent hearing loss.

#### **Triton EL Series Amplifier Features:**

- **High Efficiency Class D Circuitry** – Triton Audio has developed special circuitry that combines high thermal efficiency with Class D technology. The result is an overall efficiency of greater than 75%, something you rarely see in other designs. The result means less drain on the electrical system of the vehicle and more power directed to the speakers.
- **HFE Circuitry** – Triton Audio's engineering teams have develop High Frequency Enhancer circuitry that improves sonic performance at frequencies between 5kHz and 25kHz. Class D amplifiers in the past struggled with high frequency performance when compared to low efficiency designs such as Class AB amplifiers. With Triton Audio EL Series amplifiers this is now a thing of the past.
- **Compact Design at Affordable Prices** – High efficiency and small footprint amplifiers mean versatility in application. Triton audio EL amplifiers fit in tight spaces

#### **I. Package Contents**

- 1 EL Series Amplifier
- Warranty Card

## II. Specifications

<b>Model</b>	<b>EL6002</b>
Bridged RMS 1Ω @ 14.4V	600W
Power RMS 2Ω @ 14.4V	2 x 120W
Power RMS 4Ω @ 14.4V	2 x 85W
THD+N @ Nominal Power	<1%
Frequency Response (-3db)	20Hz ~ 20kHz
SNR	100dB
Input Sensitivity	0.2 ~ 6V
Low Pass Filter	40Hz ~ 250Hz
Damping factor (Nominal Impedance @ 100Hz)	260
Bass Boost	Adjustable 0-12dB
Bass Boost Center Frequency	45Hz
Dimensions	6.0" x 5.0" x 2.1"

### III. Installation Preparation

Please read the entire manual before installation. Due to the technical nature of amplifiers it is highly recommended that your amplifier is installed by a professional installer or an authorized dealer.

#### Before You Start

1. Disconnect negative battery terminal. (Consult a qualified technician for instructions)
2. Avoid installing the amplifier where it would be subject to high temperatures such as from direct sunlight or where it would be subject to dust or excessive vibration.
3. Use extreme caution when drilling holes to avoid damaging fuel lines or existing vehicle wiring.
4. All amplifier installations require power signal and speaker wires (not included).
5. An amplifier installation kit (sold separately) is highly recommended to facilitate the installation. Consult your dealer for recommendations.

#### Mounting Location

1. Choose a mounting location for the amplifier. Suggested locations include under a seat or in the trunk.
2. The amplifier can be mounted horizontal (recommended) or vertical. For optimum performance make sure to provide at least 1" of space around all sides. Do not mount the amplifier under carpets or where airflow is restricted.
3. Do not install the amplifier where it may be exposed to moisture.
4. The optimum mounting location varies between vehicles. Remember to test all amplifier functions before completing the final mounting procedure.

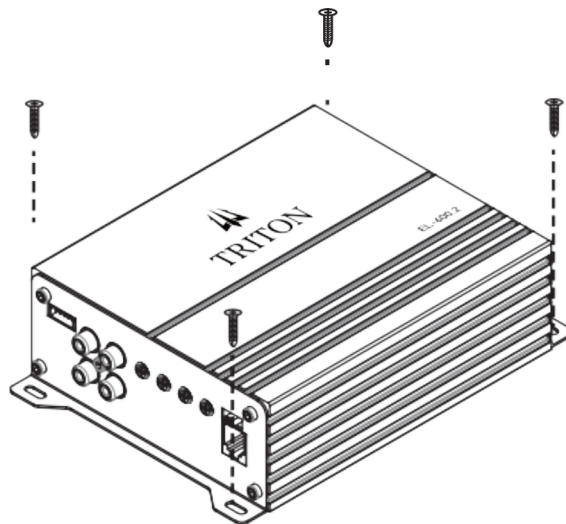

Typical  
Mounting  
Method

### III. Installation

#### Connection Descriptions

##### NOTE:

Be sure to follow specific instructions included with your amplifier installation kit (not included with this amplifier). The information below should be used as a general guideline only.

##### Power Wire (+12V)

1. Disconnect negative battery terminal before proceeding. Consult a qualified technician for instructions if you are unsure.
2. Plan wire routing before cutting any wires to length. Begin by routing the power +12V wire from the battery to the amplifier location. Use a grommet when running wires through the firewall or metal openings. Avoid running the power wire near existing vehicle wiring to prevent induced noise from entering the audio system.
3. Use extreme caution when drilling holes to avoid damaging fuel lines or existing vehicle wiring.
4. The +12V wire MUST be fused within 18" of the battery for protection of the vehicle's electrical system.

##### Ground Wire (GND)

1. The amplifier ground wire should be as short as possible (no more than 36" or 1 meter). Choose a clean unpainted section of metal or the vehicle chassis when attaching the ground connection. Be sure to clean the area of any dirt or grease.

##### Remote Turn-on Wire (REM)

1. The remote turn-on wire connects to the head unit's amplifier turn-on lead or power antenna output.

##### Speaker Wires

1. Choose adequate gauge speaker wire depending on your exact amplifier/speaker combination. Be sure to observe polarity when connecting.
2. Do not ground any speaker wires or connect any speaker wires together.

##### Input Signal

1. The amplifier's input signal connects to the head unit's low level (RCA) or high level (speaker wire) outputs.
2. Low level input signals deliver the best performance. If unavailable, use the high level inputs - when interfacing with factory head unit for instance.

##### CAUTION

1. Do not use both low and high level inputs at the same time. Connect only one or the other.
2. Keep low level inputs away from any power wires to avoid engine noise.
3. Never run any wires underneath or outside the vehicle.

### III. Installation

#### Audio Inputs and Controls

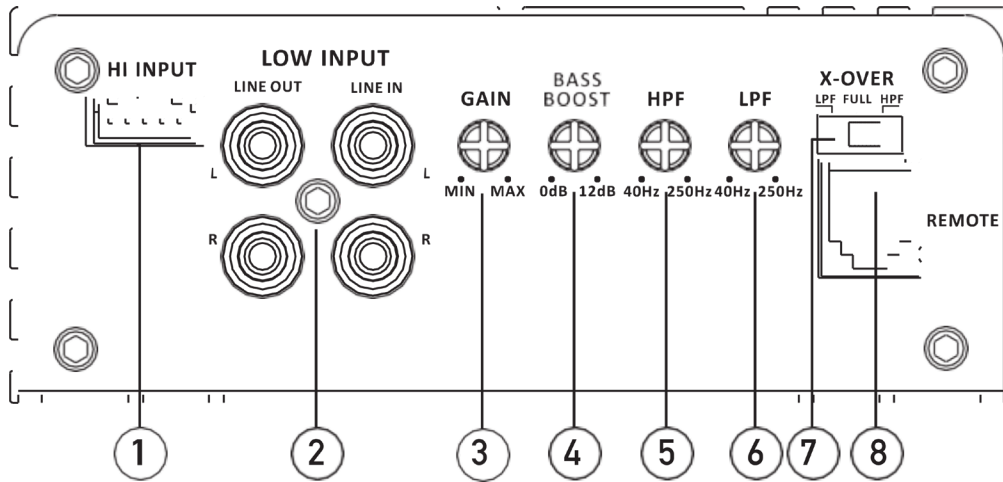

- |   |                              |
|---|------------------------------|
| <b>1</b> High-Level Inputs (Speaker Wire) | <b>5</b> High-Pass Filter    |
| <b>2</b> Line In/Line Out (RCA)           | <b>6</b> Low-Pass Filter     |
| <b>3</b> Gain                             | <b>7</b> Crossover Control   |
| <b>4</b> Bass Boost                       | <b>8</b> Remote Bass Control |

#### Power and Speaker Connections

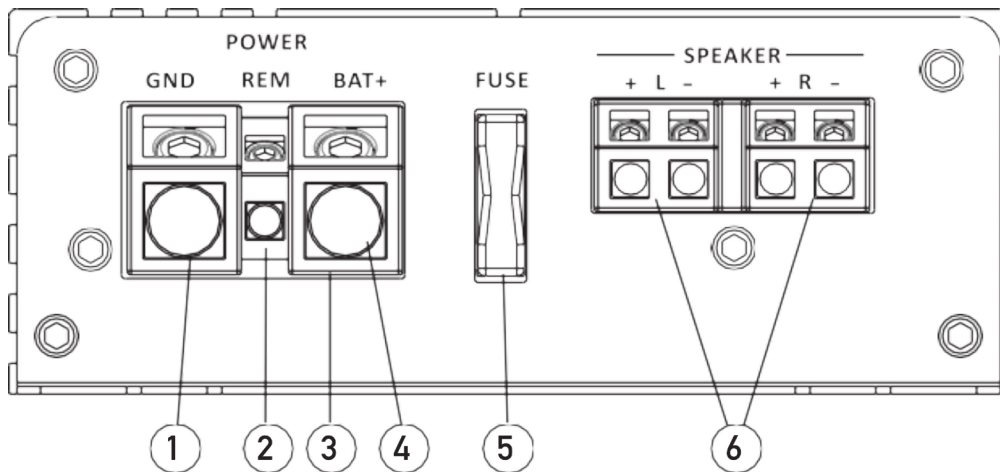

- |                            |                                    |
|----------------------------|------------------------------------|
| <b>1</b> Ground Connection | <b>4</b> +12VDC Battery Connection |
| <b>2</b> Remote Turn On    | <b>5</b> Fuse(s)                   |
| <b>3</b> Power/Protect LED | <b>6</b> Speaker Connections       |

### III. Installation

#### Typical Wire Routing

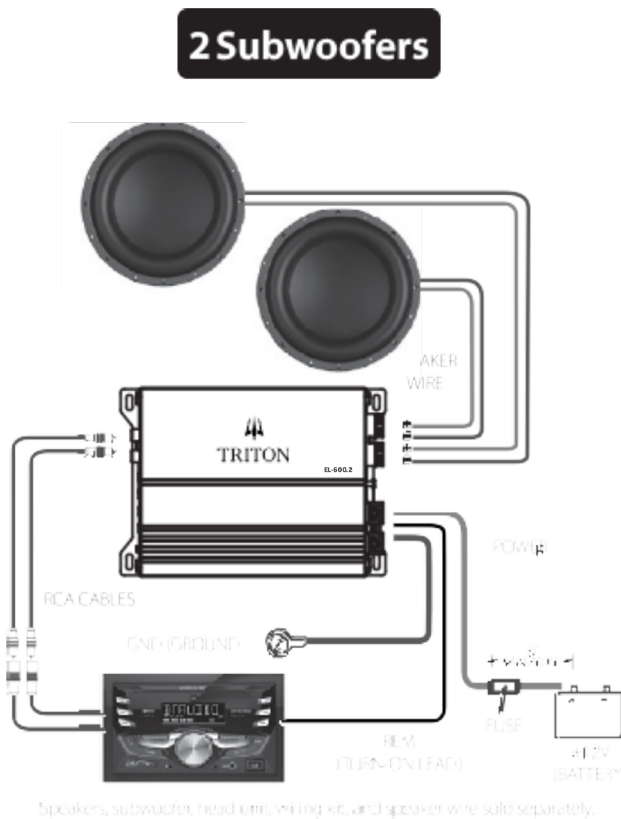
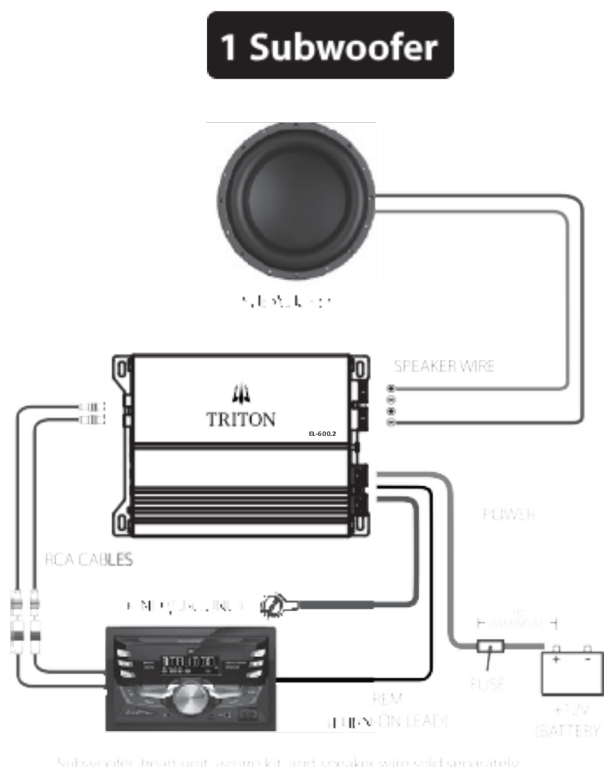
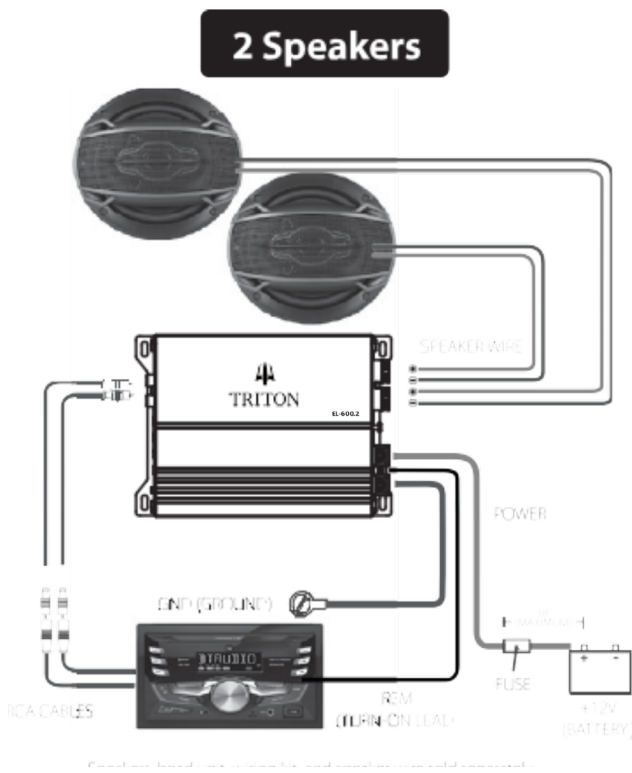

#### Main Power Connections

The illustrations on pages 6 and 7 demonstrate three different wiring options for each unit. Once desired configuration has been selected, connect the +12V, GND and REM wires accordingly. A suitable fuse MUST be installed on the +12V lead within 18" of the battery for protection of the vehicles electrical systems.



### III. Installation

#### Amplifier Connections

##### Speaker Connection

Connect speaker wires observing polarity. The minimum impedance load for the amplifiers is 2 ohms stereo and 4 ohms bridged. Use of loads lower than these is not recommended and may cause amplifier damage. The amplifiers can be wired for stereo bridged or stereo/bridged simultaneous operation.

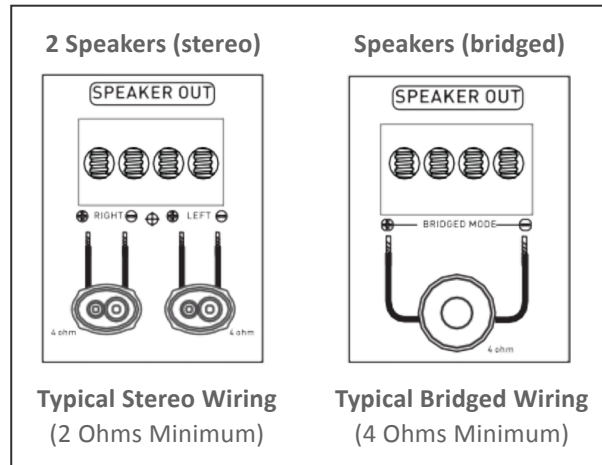

#### Input Signal Connections

##### Low Level Input (RCA)

Low level (RCA) input signal is preferred for best performance. Typical trunk-mount amplifier installations require a 17-20 foot RCA cable. Most trucks and under-seat applications require a 6-9 foot RCA cable. Using twisted pair construction RCA cables will minimize noise.

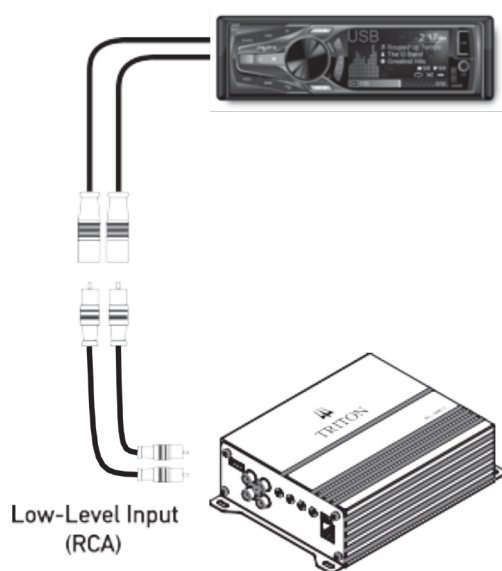

##### High Level Input (Speaker Wire)

High level inputs should only be used when RCA outputs are not available from the head unit. Connect the head unit speaker outputs to the high level input connector as shown below. The black wire (signal reference ground) may or may not require a connection to chassis ground - depending on your particular installation.

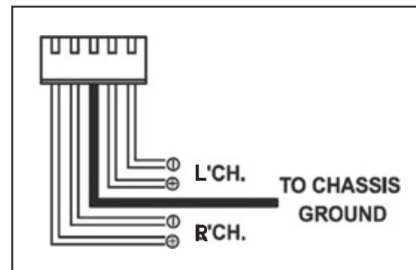

**Note:** Do not use both low and high level inputs at the same time - connect only one or the other.



### III. Installation

#### Configuration/Setup

##### Input level Control

The input level control (gain) is used to obtain the best possible match between the head unit audio output and the amplifier input. Begin by turning the input level control fully counterclockwise. Next, turn up the head unit volume control around 3/4 of the way up. Adjust the input level control clockwise until audible distortion is heard, then slightly counterclockwise to provide the best match. Repeat for all input level controls.

##### Crossover Mode

The crossover is used to filter out frequencies above or below a certain point. Choose LPF when using the amplifier with subwoofers, HPF when using with midrange/tweeter combinations and FULL when using with coaxial-type speakers.

Note: Choose FULL when using the amplifier in stereo/bridged simultaneous mode. In this mode, passive crossovers are required. Failure to use the correct passive components may damage the amplifier and/or speakers. Consult a qualified professional for recommendations.

##### Crossover Control

This control allows precise adjustment of the crossover frequency.

##### Bass Boost

This control provides additional boost @ 45Hz when used with subwoofers. Adjust this control with caution - as improper use can damage speakers!

##### Power/Protect Indicators

Colored LED indicators illuminate from the plastic power terminal. The blue LED illuminates during normal operation (POWER) and the red LED indicator is visible when the amplifier detects a fault (PROTECT).



Details and specifications mentioned in this document may be updated and subject to change without notice.  
To access the latest document please check the product website.